



1968-72 CHEVY EL CAMINO

2 Panel Sequential LED Taillight Kit Installation Guide

Kit Contents:

- **2** Taillight LED panels
- **1** Power wire with T-Tap
- **1** Driver side panel harness, 24"
- **1** Passenger side panel harness, 48"
- **2** panel extension harnesses, 12"
- **4** Mounting brackets
- **2** Cordgrip feedthroughs
- **2** Bulb plugs

PN 1101468

Note

The LED boards are shipped with the slide switch set to sequential mode. We recommend that all slide switches be set to the same setting (either standard or sequential).

Please follow all local laws concerning exterior lighting.

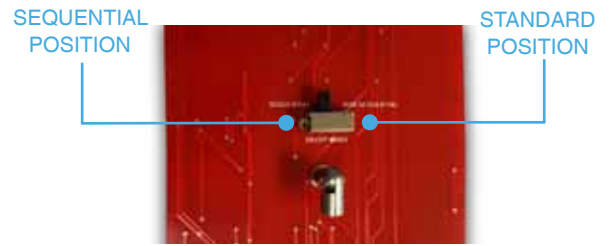

Shown in sequential mode

Hint

You may begin with the LED panel installation, however, you will need to complete the wiring modifications before the LED panels and housings are paired as one. Read over the entire instruction guide to determine the method that works best for you.

LED PANEL INSTALLATION

1. Cut off the power to your car.

Disconnect the negative terminal from the battery, which will cut off the power in your car. To verify that the power is disconnected, press the brake pedal; your brake lights should not turn on.

2. Remove the taillights.

Remove the bulbs from the sockets. Put them aside since they will no longer be needed. Pull the light sockets out from the taillight housings. Remove the taillight housing assembly from the car.

3. Identify the LED panels.

Each Taillight LED panel is marked on its backside, which identifies where each respective LED panel is to be mounted. Shown is the **DRIVER** side pane labeled **D** and the **PASSENGER** side pane labeled **P**.

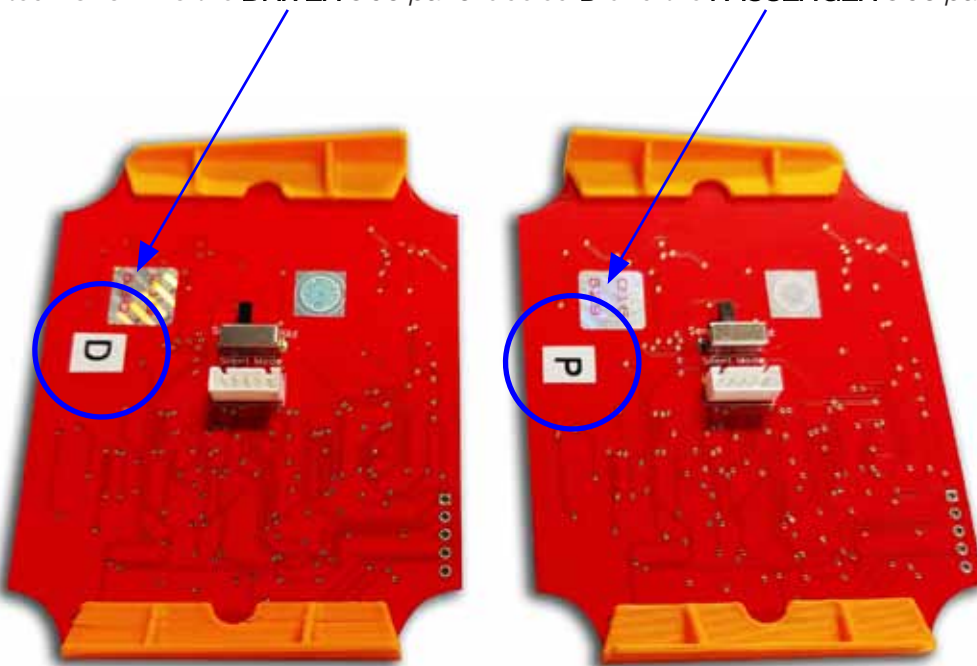

4. Remove the tail light housings and light sockets.

Remove the bulbs from the sockets. Remove the tail light housing assembly from the car. The original light sockets need to be removed. One way is to use vice grips and twist them out.



5. Install the cordgrip.

Install and tighten the cordgrip onto the housing using the socket hole. This will be used to seal the incoming wires from the elements.

1. Remove the cordgrip sealing cap. This releases the grip on the inner seal. Once the wires are through the cordgrip reinstalling the cordgrip cap will create a tight seal around

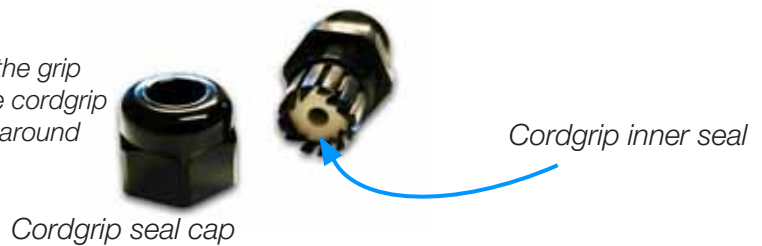

2. From the outside of the housing slide the rubber washer over the cordgrip threads then slide the cordgrip through the socket hole. From the inside of the housing screw on the lock nut and tighten.

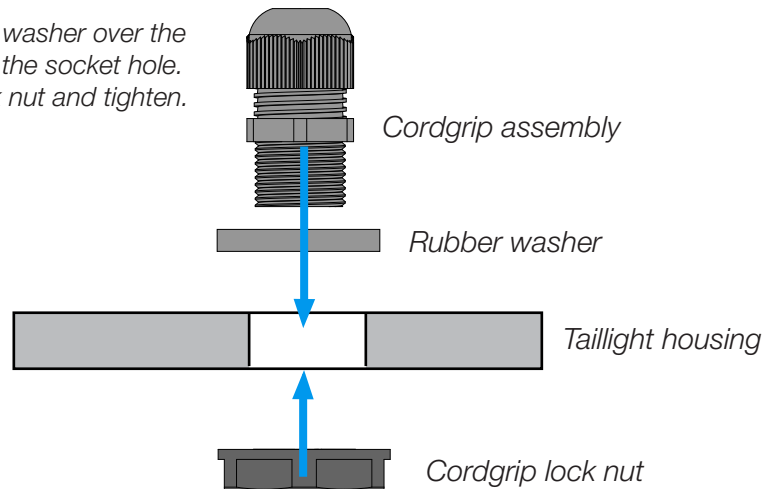

6. Install the Wire Harness

From the inside of the housing, feed a wire harness through each of the cordgrips. Pull the harness through so that the connector is pulled up near the lock nut. The shorter harness is used on the DRIVER side and the longer harness is used on the PASSENGER side housing.

1. Pull the harness through so that the connector is pulled up to towards the lock nut. If desired plug on the included EXTENSION HARNESS to add additional reach.



2. Once the harness is through retighten the cordgrip cap. this will ensure the cordgrip makes a tight seal around the wires.



7. Install the LED panels

The LED panels have mounting brackets clipped onto them. This makes installation as simple as pressing the LED panel assembly into its respective housing. You can add some silicone to the brackets to ensure they do not move.



Ensure that the edge of the bracket is lined up with the edge of the lens edge.



8. Insert bulb plug.

The side marker 194 bulb will not be used. Replace it with the included 194 cap plug.

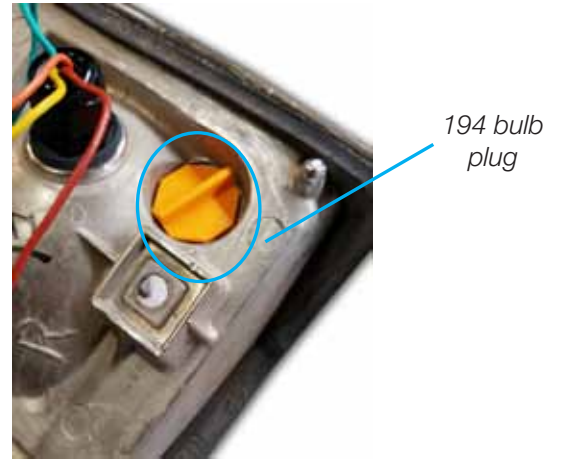

WIRE SPLICING INSTALLATION

1. Review the wiring diagrams found on the last page.









Each LED panel needs six connections. Listed are the LED harness colors and their respective function. Note: Depending on make and harness, colors may not match.

- ORANGE** - Constant 12 volt power source.
- BLACK** - Grounded to body.
- YELLOW** - Driver side turn signal.
- GREEN** - Passenger side turn signal.
- BROWN** - Running/parking light signal.

2. Find and access the taillight wires.

Pick a point in the rear body panel between the driver's side quarter panel and the driver's side taillight housing assembly and remove the cloth tape to expose the taillight wires.

3. Splice the LED SIGNAL wires into the stock SIGNAL wires. Match the LED harness to the corresponding stock harness as shown below.

LED Harness	Function	Stock harness	Notes
 Green	Passenger side turn signal/ Brake light signal	 Green	The light socket ends on the car harness can be removed.
 Yellow	Driver side turn signal/ Brake light signal	 Yellow	The light socket ends on the car harness can be removed.
 Brown	Running/Park signal	 Brown	Running light wires.
 Orange	Constant 12 volt		Find power at fuse panel/trunk light/dome light/fused battery feed.
 Black	Ground		Ground to Body/chassis

Note about brake lights

There is no dedicated Brake light signal wire. When the brake pedal is pressed the brake switch sends power into the turn signal switch and then power through both the driver and passenger signal wires to activate the brake lights.

4. Connect all the ground wires.

Connect all the ground wires together. Bolt them to the trunk latch support along with the original rear body harness ground. The ground connection must be good in order to operate the LED tail lights.

5. Supply the LED panel harnesses with a constant 12 volt feed using the included Orange power wire and T-Tap.

An Orange power wire is supplied along with a T-Tap. The orange power wire must be powered with a constant 12 volt battery supply for the LED circuitry to operate properly. You can use the included T-Tap connector to splice to a constant power source, like the dome light, trunk light, fuse box, etc.

Splice the T-Tap connector over the constant power source, then plug the orange wire into the T-Tap. The other end of the orange power wire is tied in with the orange wires of all the LED panel harnesses.



1. Insert wire into T-Tap



2. Crimp with pliers



3. Plug connector into T-Tap

6. Tuck and secure the spliced wires.

Take the spliced sections and fold them over to one side and tape them in place. This will allow you to place the wiring into loom or wrap the LED panel wiring tightly away.



1. Fold wires to one side.



2. Secure with electrical tape.

Note

A wire diagram of the LED panel's harness spliced into the car's stock harness is on the last page.

Note

The LED light kits are designed for best performance when use an electronic no-load flasher. Shown here is an optional electronic no load flasher available from DIGI-TAILS, (PN 20-F2)



If you decide to use a stock bimetal flasher, we recommend a standard-duty flasher instead of a heavy-duty flasher. If your turn signal circuit includes front and rear LED turn signals, the circuit will not have enough resistance load to operate a heavy-duty bimetal flasher, so the no-load flasher will be required for both the turn signal and emergency flashers.

